

Aviation Ground Fuelling Solutions

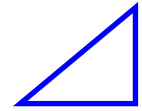

Fuelling products

Hydrant Pit Box

Distance Ring & Bolts

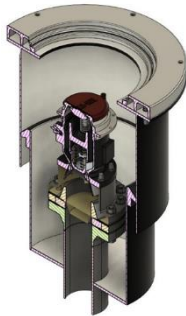

We develop creative, comprehensive, and sustainable engineering solutions for a future where customers can thrive.

Equipped with an intimate understanding of local intricacies, world-class talent, and proactive leadership, we design in close cooperation with our customers modular, flexible start to the art ground fueling equipment.

Benefits

- The Distance Rings are available in standard dimensions
- Installation Kit with stud bolts, nuts, sleeves, and gaskets available.
- Tested with 24 bar
- Independently certified with 3.2 certificate

Additional Features

- Design easily customized for specific applications
- Accepts all valves meeting IP & API recommendations
- Gasket for ease of maintenance

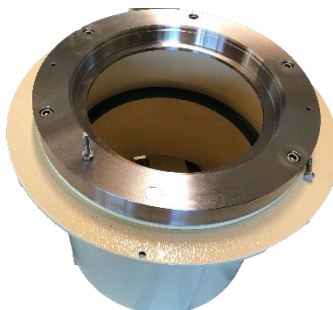

Key Features

- Design: AD2000 ASME
- Material: 1.4301
- Mechanical work: all sides lathed
- Test: Water pressure with 24bar
- Certificates: Distance Ring 3.2 Stud bolts 3.1
- API/IP - 1584
- EI - 1540
- EI - 1542
- AIR BP REF: Mech 30

Optional

- Gasket Flat 6" RF 300lbs
- Stud Bolts M20 - DIN 939
- Nut M20 - DIN 934
- Sleeve 21x37x3 DIN 125

AMEC-EUROPE LTD.

Aviation Ground Fuelling Solutions

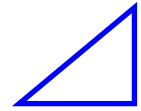

Technical details

High Distance Ring [mm]	Lengh Stud bold M20 [mm]	Qty	Material	Norn
10	100	12	A2-70	DIN 938
15	110	12	A2-70	DIN 938
20	110	12	A2-70	DIN 938
25	120	12	A2-70	DIN 938
30	120	12	A2-70	DIN 938
35	130	12	A2-70	DIN 938
40	130	12	A2-70	DIN 938
45	140	12	A2-70	DIN 938
50	140	12	A2-70	DIN 938
55	150	12	A2-70	DIN 938
60	150	12	A2-70	DIN 938

AMEC-EUROPE LTD.

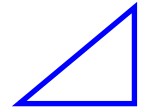

Dimensions & Schematic view

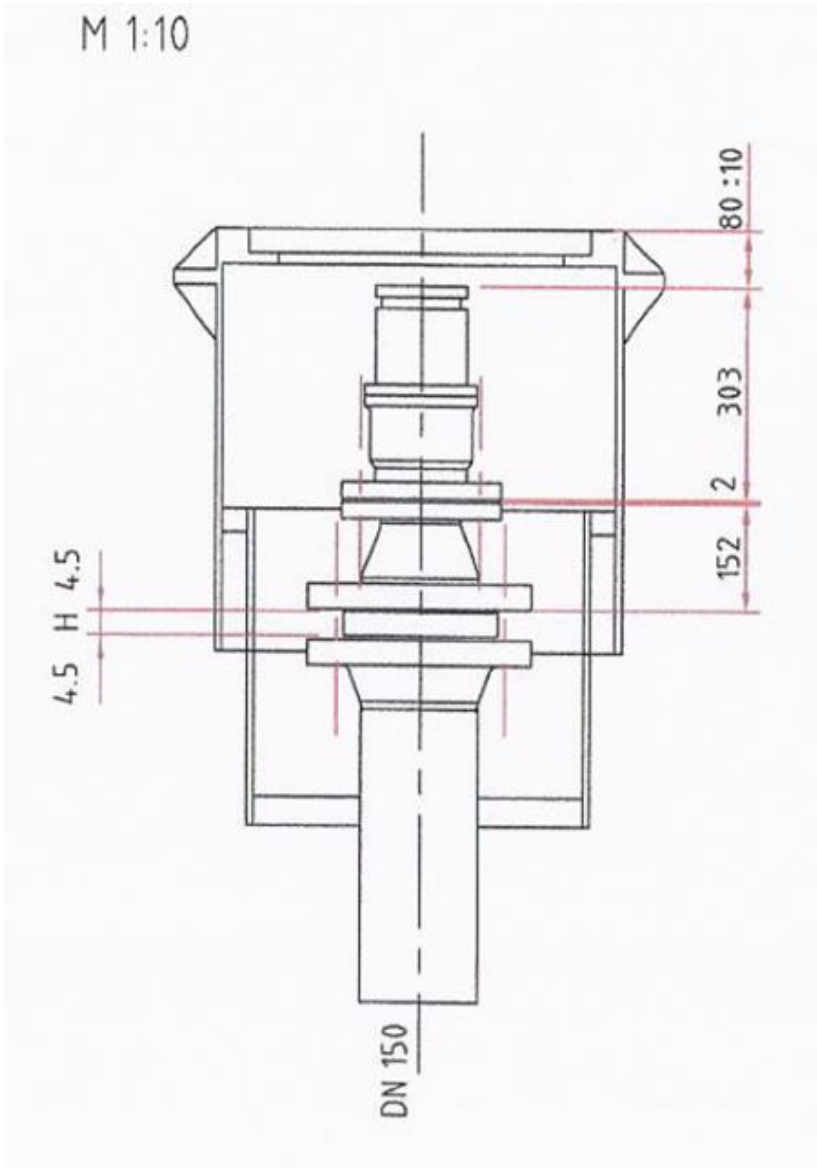

Distance Ring

Design: AD2000; ASME

Material: 1.4301

Mechanical work: all sides lathed

Test: Water pressure with 24bar

Certificates: Distance Ring 3.1; Stud bolts 3.1

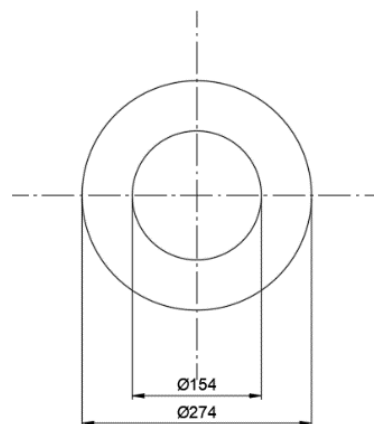

Aviation Ground Fuelling Solutions

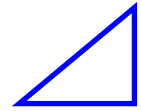

Accessories

- Gasket Flat 6" RF 300lbs
- Stud Bolts M20 - DIN 939 (1.25D)
- Material: 1.4301
- Nut M20 - DIN 934 - Material: 1.4301
- Sleeve 21x37x3 - DIN 125
- Material: 1.4301

Other hydrant pit products

- AMEC Pit Box
 - WL4354
 - WL5225
 - WL6000
 - WL7900
 - WL3640
 - WL4354-S
 - WL5225-S
- AMEC Pit Lid
 - WL4865
 - WL6000 (Dia. 20")
 - WL6000 (Dia. 22")
- AMEC Shoulder Ring
 - SR4865
 - SR6000 (Dia. 20")
 - SR6000 (Dia. 22")
- AMEC High-Low Point
 - WL4231
- AMEC Accessory
 - Distance Ring
 - WL6000 Elevation Ring
- CLA-VAL
 - Hydrant Pit Valve
 - Hydrant Isolation Valve
- Rolling Cover Pit Assembly
- AMEC Heated Hydrant Pit Box Kit
 - For artic use
 - Ex-Zone approved.
- AMEC Hydrant Pit Box Draining
 - 1" bottom access for central draining
- AMEC Consulting Service

Distribution/Partners

Africa



e'Afrifil (Pty) Ltd.
1 Cnr Chilworth & Pressburg Roads
ZA 1645 Johannesburg
Tel. +27 11 452 5444

Asia



FLOWCO ASIA PACIFIC (PTE) LTD
Mailing Address: Tampines Central P.O. Box 0266 Singapore 915209
3018 Bedok North St 5 #01-21 EASTLINK Singapore 486132
Tel: (65) 6542 4707 Fax: (65) 6542 4702 Email: Flowco@singnet.com.sg

Australia/South Pacific



148 Newton Road Wetherill Park NSW
2164 Australia Tel +61 490 428 863

America



Mr. T. Landmann
Phone: +44(0)784 6941 664
E-mail: sales@amec-europe.com

EUROPE



Mr. T. Landmann
Phone: +44(0)784 6941 664
E-mail: sales@amec-europe.com

India



E-71, Additional MIDC Patalganga
Karade Khurd, Tal: Panvel, Dist: Raigad,
Maharashtra 410220 – INDIA
Phone: +91 21 92 25 22 98-99
E-Mail: welcome@titan-asia.com

Manufacturer



Please contact our sales for further
Information at www.agfs.aero

AMEC-EUROPE LTD.

Note: specifications are subject to change without notice.